

Pressure Regulator compact 8011

GS 3 series - DN 15 up to DN 150



Self operated regulation of inlet and outlet pressures of neutral through to highly aggressive media in process engineering, chemical industries and for plant equipment.

- Space saving wafer type design
- Lowest possible weight
- High Kvs-values



Technical Information

Body design	Flangeless, wafer-type construction ore versions see on data-sheet 8010-GS1		
Nominal sizes	DN 15 to DN 150		
Nominal pressure acc. DIN 2401 for flanges with facing type B	PN 40 (fits also to PN 10-25)	DN 15 - DN 150	
Nominal pressure acc. ANSI for flanges acc. ASME B16.5 RF	ANSI 150 ANSI 300	DN 15 - DN 150 DN 15 - DN 150	
Nominal pressure acc. JIS for „raiced face“ flanges	10K 20K	DN 15 - DN 50 DN 15 - DN 40	
Pressure range	0,3 up to 10 bar (see table)		
Operating pressures	Limited to applications of category I of the Pressure Equipment Directive 2014/68/EU		
Media temperature	-60°C up to +230°C at special versions up to 300°C		
Max. ambient temperature	+80°C		
Max. working temperatures for the actuator	Diaphragm material CR: EPDM: EPDM (FDA): FKM:	-20°C up to +80°C -30°C up to +130°C -30°C up to +130°C -15°C up to +150°C	
Leakage % of Kvs IEC 60534-4 EN 12266-1	Disc pair Carbon-stainless steel < 0,0001 IV-S1 E	Disc pair SFC < 0,0005 IV-S1 F	Disc pair STN 2 < 0,001 IV F
Spezific leakage rate shaft and body sealing	ISO FE-BH-CC3-SSA0-t(-40°C/+350°C)-PN40-ISO 15848-1		

* With DN15 with reduction of less than 25%, different leakage rates possible.
K_{vs}-values see data sheet 8001.

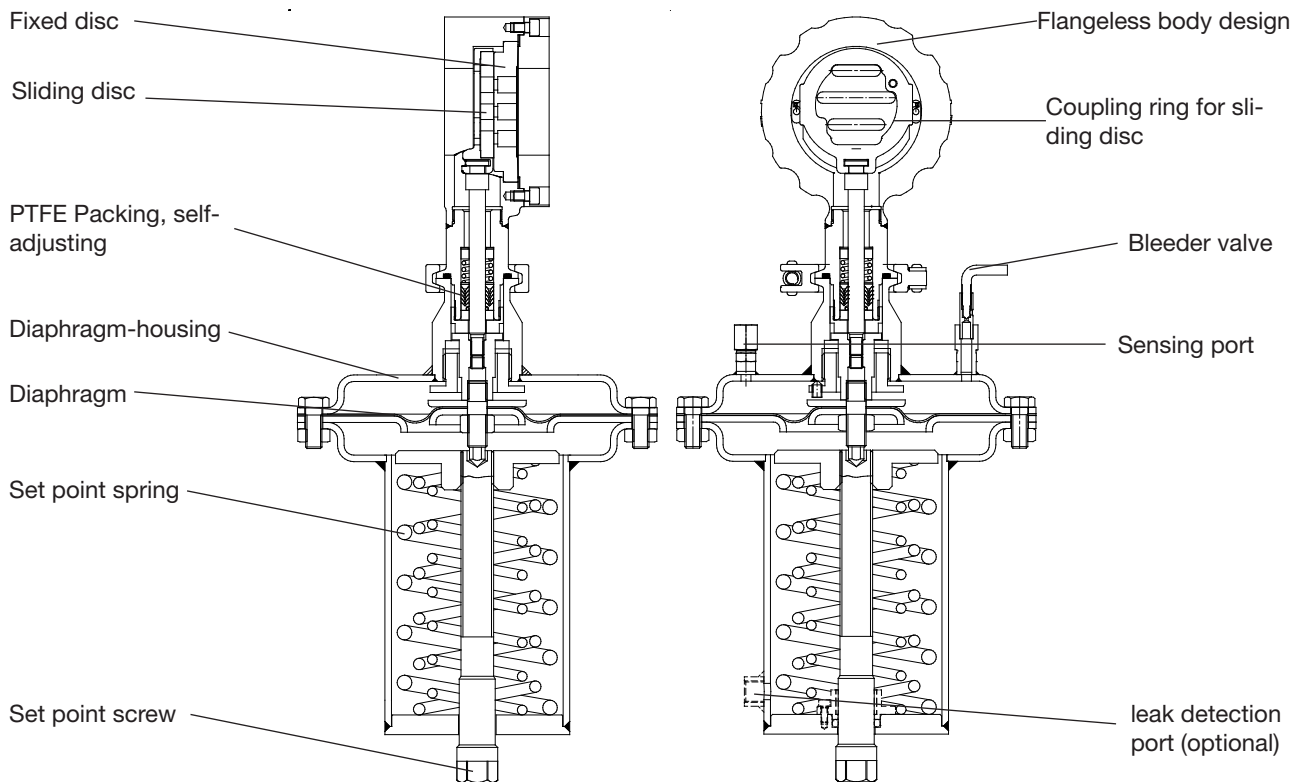

Pressure Regulator compact 8011-GS3



without supply energy

**Admissible differential pressures
(For temperatures of up to 120°C with PN-rating
up to 38°C with ANSI-rating)**

**For temperatures of 120°C (PN) or
38°C (ANSI) and above:
obey application limits !**

**Disc pair: carbon - stainless steel
SFC - stainless steel**

Disc pair: STN 2

Maximum admissible differential pressures for pressure regulator (output pressure regulator)

Pressure range (bar) output pressure P2	4 to 10	2 to 5	1 to 2,5	0,3 to 1,2
Diaphragm: Diameter (mm)	220	220	220	220
Surface area (cm ²)	40	80	176	176
DN 15	40	40	40	40
DN 20	40	40	40	38
DN 25	40	40	40	24
DN 32	31	31	31	16
DN 40	20	20	22	10
DN 50	11	11	12	5,6
DN 65	9	9	10	4,5
DN 80	5	5	6	2,6
DN 100	3,2	3,2	3,6	1,6
DN 125	2	2	2,4	1,1
DN 150	1,5	1,5	1,7	0,8

Maximum admissible differential pressures for pressure regulator (output pressure regulator)

Pressure range (bar) output pressure P2	4 to 10	2 to 5	1 to 2,5	0,3 to 1,2
Diaphragm: Diameter (mm)	220	220	220	220
Surface area (cm ²)	40	80	176	176
DN 15	40	40	40	21
DN 20	30	30	33	12
DN 25	19	19	21	8
DN 32	11	11	13	5
DN 40	7	7	8	3,3
DN 50	4	4	4,5	1,8
DN 65	3	3	3,5	1,5
DN 80	1,8	1,8	2	0,8
DN 100	1	1	1,2	0,5
DN 125	0,7	0,7	0,8	0,3
DN 150	0,5	0,5	0,5	0,25

overflow (inlet pressure regulator)

Pressure range (bar) inlet pressure P1	4 to 10	2 to 5	1 to 2,5	0,3 to 1,2
Diaphragm: Diameter (mm)	220	220	220	220
Surface area (cm ²)	40	80	176	176
DN 15	10	5	2,5	1,2
DN 20	10	5	2,5	1,2
DN 25	10	5	2,5	1,2
DN 32	10	5	2,5	1,2
DN 40	10	5	2,5	1,2
DN 50	10	5	2,5	1,2
DN 65	9	5	2,5	1,2
DN 80	5	5	2,5	1,2
DN 100	3,2	3,2	2,5	1,2
DN 125	2	2	2,4	1
DN 150	1,5	1,5	1,7	0,8

overflow (inlet pressure regulator)

Pressure range (bar) inlet pressure P1	4 to 10	2 to 5	1 to 2,5	0,3 to 1,2
Diaphragm: Diameter (mm)	220	220	220	220
Surface area (cm ²)	40	80	176	176
DN 15	10	5	2,5	1,2
DN 20	10	5	2,5	1,2
DN 25	10	5	2,5	1,2
DN 32	10	5	2,5	1,2
DN 40	7	5	2,5	1,2
DN 50	4	4	2,5	1,2
DN 65	3	3	2,5	1,2
DN 80	1,8	1,8	2	0,8
DN 100	1	1	1,2	0,5
DN 125	0,7	0,7	0,8	0,3
DN 150	0,5	0,5	0,5	0,25

application limits according to Category I of the Pressure Equipment Directive 2014/68/EU

		Maximum permissible operating pressure in bar for applications of category I of the Pressure Equipment Directive 2014/68/EU										
		DN15	DN20	DN25	DN32	DN40	DN50	DN65	DN80	DN100	DN125	DN150
Fluid group 1	gaseous	X	X	X	31,3	25,0	20,0	15,4	12,5	10,0	Not permissible	Not permissible
	liquid	X	X	X	62,5	50,0	40,0	30,8	25,0	20,0	16,0	13,3
Fluid group 2	gaseous	X	X	X	X	X	X	X	X	X	28,0	23,3
	liquid	X	X	X	X	X	X	X	X	X	X	X

X = No limit

The actuator should be of a size that allows an adjustment at the upper limit of the pressure range.

Pressure Regulator compact 8011-GS3



without supply energy

Materials

Body	Stainless steel 1.4408		
Bodycover	Stainless steel 1.4571 or 1.4404		
Diaphragm housing	Stainless steel 1.4571		
Diaphragm	CR, EPDM, FKM, PTFE-foil		
Spring	Stainless steel 1.4310		
Stem	Stainless steel 1.4571, roller burnished		
Fixed disc	Stainless steel 1.4571, coated		STN2-disc
Sliding disc	Special carbon material	SFC-disc	STN2-disc
Guide ring for sliding disc	Stainless steel 1.4581		

Ordering Number System

8	0	1	1	/				V	D	K					M						S
---	---	---	---	---	--	--	--	---	---	---	--	--	--	--	---	--	--	--	--	--	---

1 - 5 : Please quote all 5 sections.
6 - 12: Quote only if required.

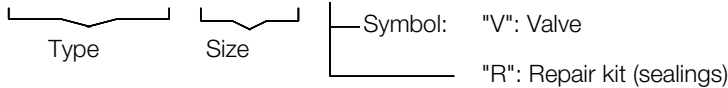

1. Function	2. Design	3. Body design	4. Version	5. Function	6. Pressure range
D Pressure regulator compact (Type 8011)	K Compact design	E GS3 - flangeless design acc. ANSI 150 F GS3 - flangeless design acc. ANSI 300 G GS3 - flangeless design acc. DIN, PN10 - PN40	2 Completely stain-less 5 Completely stain-less with controlling connection G 1/4"	0 Overflow 1 valve Pressure regulator	0 4 - 10 bar 1 2 - 5 bar 2 1 - 2,5 bar 3 0,3 - 1,2 bar
7. Special version	8. Diaphragm material	9. Sliding disc	10. Fixed disc	11. Kvs-values	12. Special versions
M To state, if further sections are quoted	- CR (Standard) 1 EPDM 2 FKM 3 CR+PTFE-foil 4 EPDM + PTFE-foil 5 FKM + PTFE-foil 6 EPDM (FDA)	- carbon material 9 STN2 S SFC	- stainless steel 1.4571 1 STN2	- 100 % (Stand.) A red. to 63 % 1 red. to 40 % B red. to 25 % 2 red. to 16 % C red. to 10 % 3 red. to 6,3 % 4 red. to 2,5 % 5 red. to 1 % 7 red. to 12 % 8 red. to 2 %	S Quote for further special versionsw

Ordering example: 8011/080VDKG210M1- -1
GS3-pressure regulator, DN80, compact design, PN 10/40, completely stainless steel, spring cap closed, pressure regulator, pressure range 4-10 bar, diaphragm material EPDM, sliding disc carbon material, fixed disc, stainless steel 1.4571, reduced Kvs-value (40%)

without supply energy

Application limitations for GS3 valves in stainless steel

These pressure must not be exceeded for GS-valves from the GS3-series made of stainless steel, even though the actuator power might allow it.

PN40

DN	Sliding unit: carbon/SFC - stainless steel, coated							
	max. admissible pressures for GS3-valves in carbon steel							
	100°C	150°C	200°C	250°C	300°C	350°C	400°C	450°C
15-32	40	40	40	40	40	40	40	40
40	40	40	40	40	40	40	40	40
50	40	40	40	40	40	40	40	40
65	40	40	40	40	40	40	40	40
80	40	40	40	40	40	40	40	38
100	33	33	33	33	33	33	33	33
125	23	23	23	23	23	23	23	23
150	16	16	16	16	16	16	16	16
200 (only PN16)	16	16	15	13	12	11	10	9
250 (only PN16)	10	9	9	8	7	6	6	5

ANSI150

DN	Sliding unit: carbon/SFC - stainless steel, coated								Sliding unit: STN2							
	max. admissible pressures for GS3-valves in carbon steel								max. admissible pressures for GS3-valves in carbon steel							
	38°C	50°C	100°C	150°C	200°C	250°C	300°C	350°C	38°C	50°C	100°C	150°C	200°C	250°C	300°C	350°C
15-125	19,6	19,2	17,7	15,8	13,8	12,1	10,2	8,4	19,6	19,2	17,7	15,8	13,8	12,1	10,2	8,4
150	16,0	16,0	16,0	15,8	13,8	12,1	10,2	8,4	16,2	16,2	16,2	15,4	13,8	11,8	9,7	8,0
200	16,0	16,0	16,0	15,8	13,8	12,1	10,2	8,4	-	-	-	-	-	-	-	-
250	10,5	10,5	10,5	9,9	9,4	8,4	7,4	6,0	-	-	-	-	-	-	-	-

Limitation for SFC-sliding discs: 300°C

ANSI300

DN	Sliding unit: carbon/SFC - stainless steel, coated								Sliding unit: STN2							
	max. admissible pressures for GS3-valves in carbon steel								max. admissible pressures for GS3-valves in carbon steel							
	38°C	50°C	100°C	150°C	200°C	250°C	300°C	350°C	38°C	50°C	100°C	150°C	200°C	250°C	300°C	350°C
15-50	51,1	50,1	46,6	45,1	43,8	41,9	39,8	37,6	51,1	50,1	46,6	45,1	43,8	41,9	39,8	37,6
65	51,1	50,1	46,6	45,1	43,8	41,9	39,8	37,6	41,7	41,7	41,7	39,7	37,6	33,5	37,6	33,0
80	48,0	48,0	46,6	45,1	43,8	41,9	39,8	37,6	36,6	36,6	36,6	34,8	33,0	26,8	22,0	19,0
100	33,0	33,0	33,0	33,0	33,0	33,0	33,0	33,0	33,0	33,0	33,0	31,7	30,1	24,4	20,0	17,5
125	23,0	23,0	23,0	23,0	23,0	23,0	23,0	23,0	22,1	22,1	22,1	21,0	19,9	16,1	13,2	11,5
150	16,0	16,0	16,0	16,0	16,0	16,0	16,0	16,0	16,0	16,0	16,0	15,4	14,6	11,8	9,7	8,4

Limitation for SFC-sliding discs: 300°C

without supply energy

Dimensions and Weights

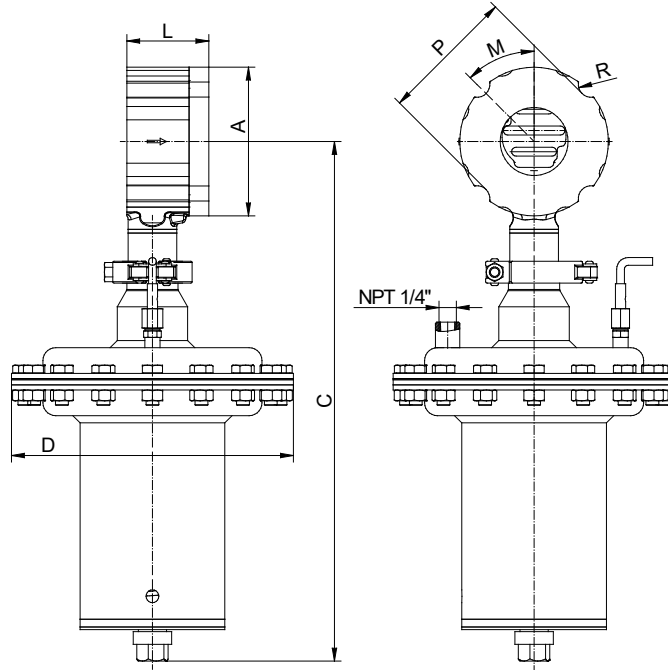

DN	Weight in kg for pressure range (bar)			
	4 - 10	2 - 5	1 - 2.5	0.3 - 1.2
15	11,2	11,2	10,1	9,3
20	11,4	11,4	10,3	9,5
25	12,3	12,3	11,2	10,4
32	12,7	12,7	11,6	10,8
40	13,1	13,1	12	11,2
50	15,2	15,2	14,1	13,3
65	17	17	15,9	15,1
80	18,1	18,1	17	16,2
100	22,1	22,1	21	20,2
125	26,3	26,3	25,2	24,4
150	30	30	28,9	28,1

DN	Ø A	D	C max.	Stroke	PN40			ANSI150			ANSI300			R	L
					P	M	Number „R“	P	M	Number „R“	P	M	Number „R“		
15	64	220	389	6	53	45	4	48,8	45	4	53	45	4	8	56
20	72	220	393	6	63	45	4	58,2	45	4	68	45	4	10	56
25	82	220	398	6	73	45	4	67,6	45	4	73	45	4	10	56
32	89	220	401	6	83	45	4	77	45	4	83	45	4	10	56
40	99	220	406	6	94	45	4	87	45	4	94	45	4	10	56
50	116	220	416	8	115	45	4	106	45	4	112	22,5	8	10	64
65	138	220	425	8	129	22,5	8	125	45	4	129	22,5	8	10	68
80	153	220	434	8	144	22,5	8	138	45	4	150	22,5	8	10	70
100	184	220	456	8,5	164	22,5	8	176	22,5	8	182	22,5	8	10	75
125	212	220	470	8,5	194	22,5	8	194	22,5	8	212	---	0	0	80
150	242	220	483	8,5	220	22,5	8	220	22,5	8	242	---	0	0	80

Dimensions in mm